

Nozzel Connection Table			
Conn.	Size	Type	Despriction
N1	N/A	Custom Flange- 304SS	Float Mechanism
N2	∅ 1/2"	NPT - 304SS	Motive Steam Inlet
N3	∅ 3/4"	NPT - 304SS	Vent
N4	∅ 2"	NPT - 304SS	Condensate Inlet
N5	∅ 2"	NPT - 304SS	Condensate Outlet
N6	∅ 1/2"	NPT - 304SS	Drain

D

C

B

A

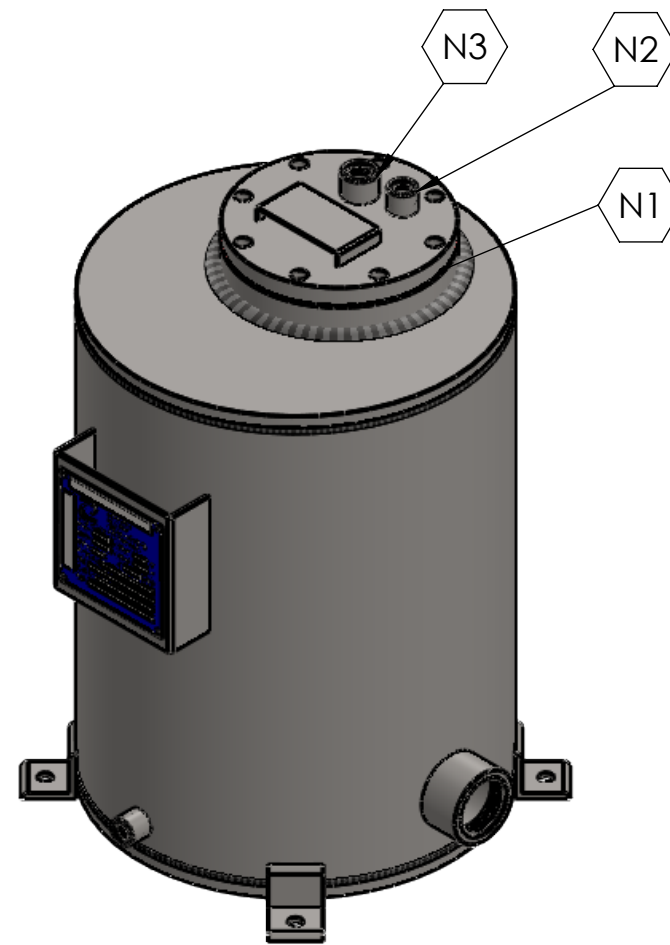
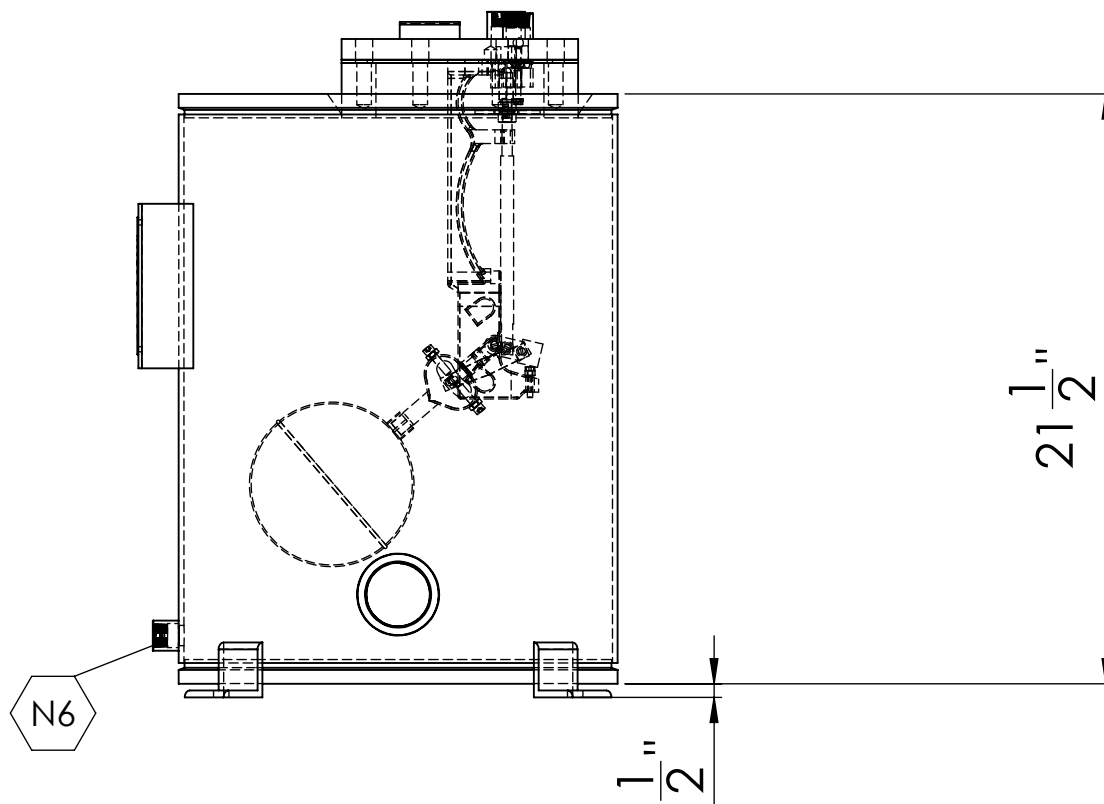
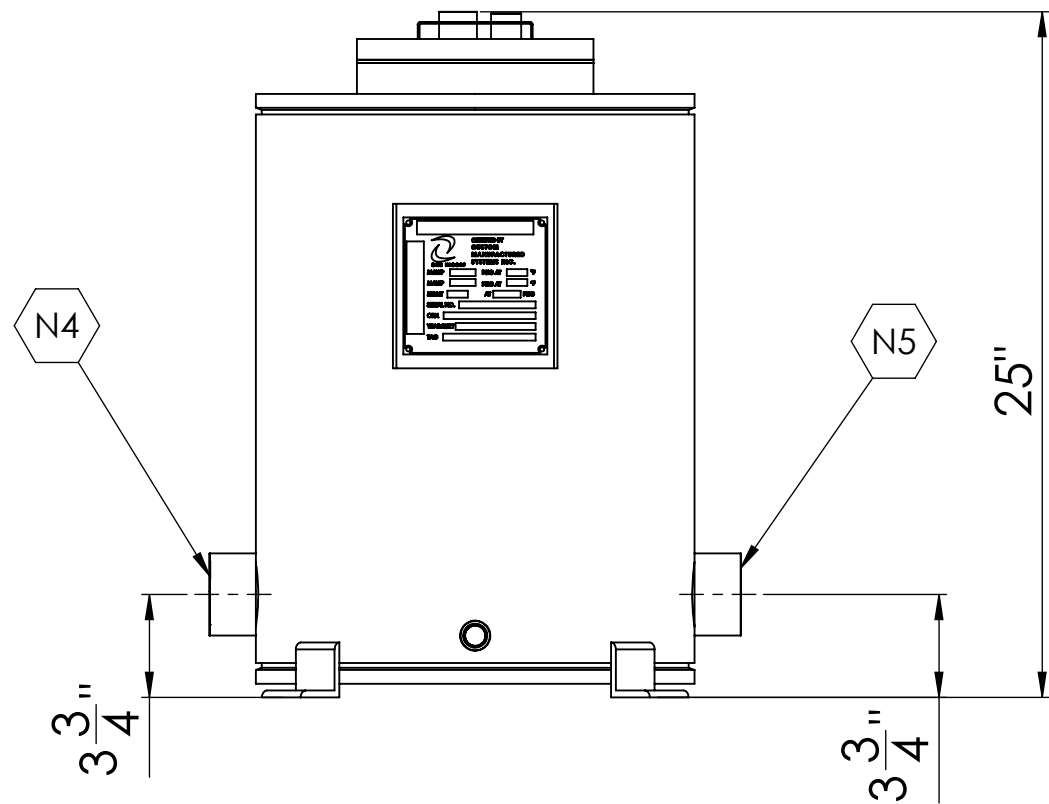
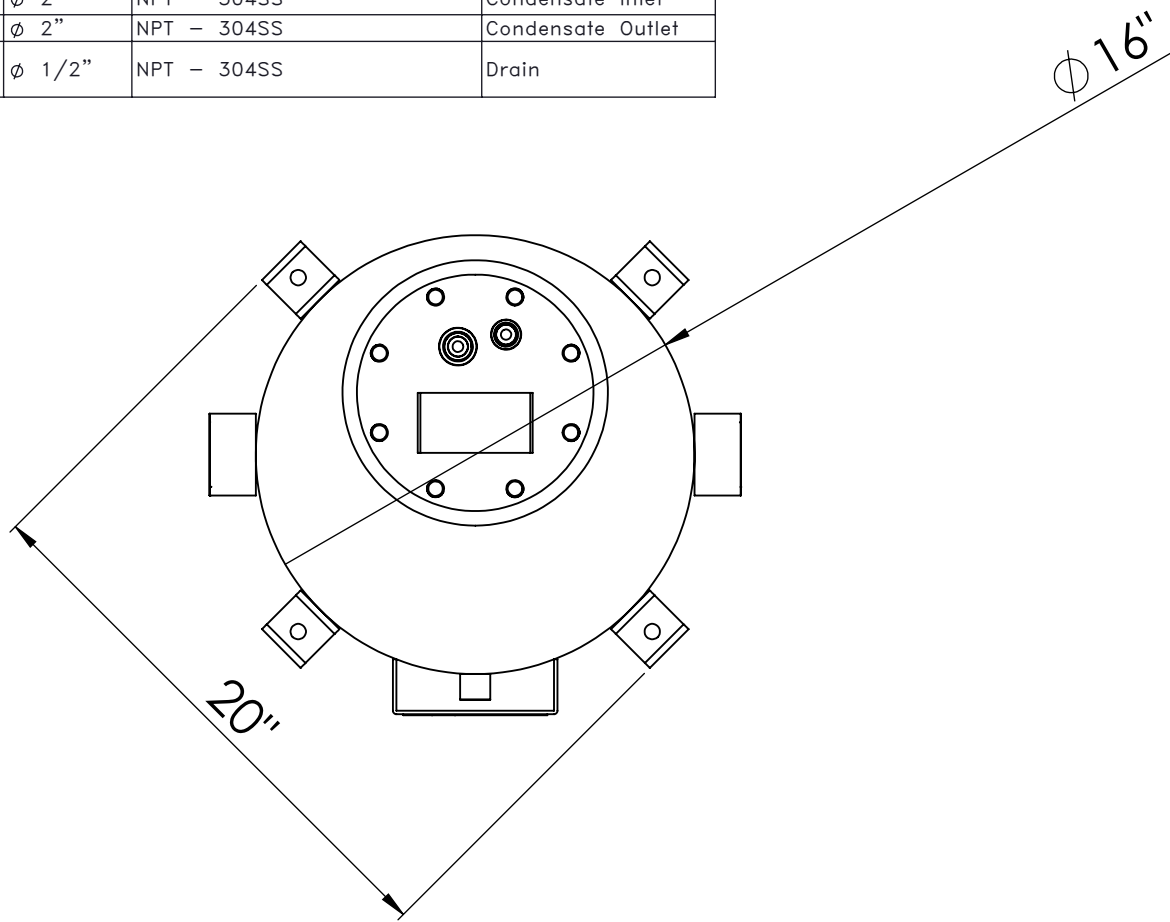

NOTES:

*17 US GALLON CAPACITY
 *150 LB DESIGN
 *MOC-304 SS

-	-	-	-
-	-	-	-
-	-	-	-
-	-	-	-
01	N3 TO 3/4"	21/12/20	KK
REV. NO.	DESCRIPTION:	DATE:	BY:

ENGINEER:

PROJECT:
 CUSTOM STEAM MOTIVE
 CONDENSATE PUMPS

CLIENT/CUSTOMER:
 STOCK ITEM

PAGE DESCRIPTION:
 STEAM MOTIVE CONDENSATE PUMP

MODEL #:
 CND-MP-304SS-150

WORK ORDER #:

SCALE: 1:7 DWG SIZE: B SHEET: 1 OF 1

DRAWN BY: KEENAN KELLY DATE: 24/11/20
 APPROVED BY: AD DATE: 25/11/20
 CHECKED BY: KM DATE: 25/11/20



Custom Steam Solutions Inc

Your Steam System Integrators

ESTIMATED DRY WEIGHT:
 183.17 - LBS

PROPRIETARY AND CONFIDENTIAL
 THIS DOCUMENT CONTAINS PRIVILEGED AND CONFIDENTIAL PROPERTY OF CUSTOM STEAM SOLUTIONS INC. ANY DISCLOSURE OR REPRODUCTION IN PART OR AS A WHOLE WITHOUT THE WRITTEN PERMISSION OF CUSTOM STEAM SOLUTIONS INC. IS PROHIBITED.

DRAWING #: 179-C003

REV #: 01

8

7

6

5

4

3

2

1

8

7

6

5

4

3

2

1